

Sammode — Pierre Guariche

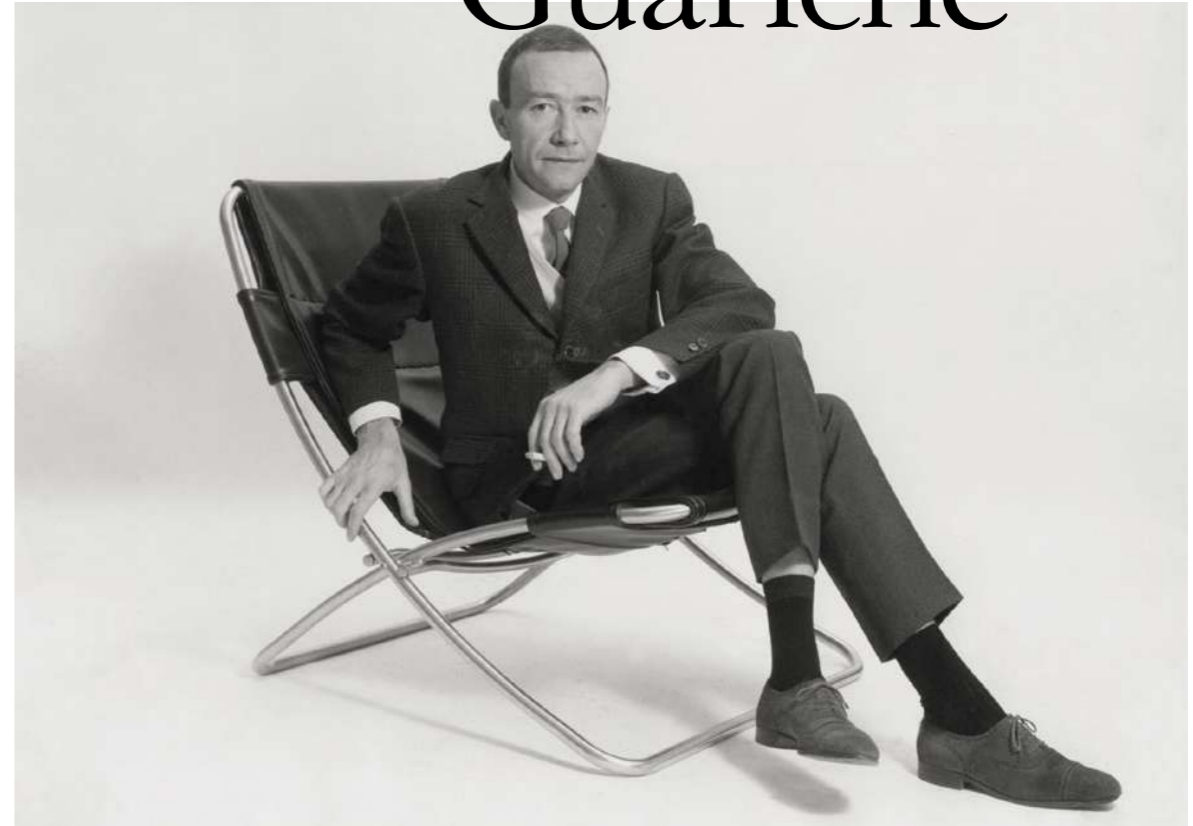

Sammode — Pierre Guariche





Sammode – Pierre Guariche			4
G1	Lampadaire Suspension Applique	Floor lamp Pendant lamp Wall lamp	8
G2	Lampadaire	Floor lamp	12
G3	Applique	Wall lamp	16
G3T	Applique	Wall lamp	18
G13	Plafonnier	Ceiling lamp	20
G13A	Suspension	Pendant lamp	22
G21	Lampadaire	Floor lamp	24
G24	Lampe à poser	Table lamp	28
G25	Applique Suspension	Wall lamp Pendant lamp	32
G30	Lampadaire	Floor lamp	36
G32	Applique	Wall lamp	40
G320	Applique	Wall lamp	42
G50	Lampe à poser	Table lamp	44
G54	Lampadaire	Floor lamp	48
G60	Lampe à poser	Table lamp	52
G61	Lampe à poser	Table lamp	54
Synopsis de la collection			56
		Collection Summary	56

Sammode — Pierre Guariche



Applique G1, créée en 1951 | Wall lamp G1, created in 1951.



Le lampadaire G54, créé en 1959 | The floor lamp G54, designed in 1959.

Sammode réédite une sélection de luminaires imaginés dans les années 1950 par l'un des créateurs-phares français : Pierre Guariche.

S'il est un domaine dans lequel il excellait, c'est bien le luminaire. Le designer et architecte d'intérieur Pierre Guariche en est un des créateurs les plus féconds des années 1950. En témoigne sa fructueuse collaboration avec l'éditeur de lampes Disderot, dont il fut, à cette période, le concepteur attitré et pour lequel il développa plus d'une quarantaine de spécimens qui ont marqué leur époque.

Pierre Guariche a conçu une gamme complète de luminaires ou, plus exactement, des « familles » — lampe de bureau, lampadaire, applique, suspension... —, qui combinent tous les besoins identifiés de chaque espace. Ses luminaires offrent un grand confort d'utilisation — aucune source lumineuse n'est apparente — et une qualité de lumière idoine : éclairage général ou de circulation, d'ambiance ou ponctuel, doux ou puissant, voire diffusé par réflexion.

Que Sammode choisisse aujourd'hui de rééditer certains de ces modèles est tout sauf un hasard. Depuis nombre d'années en effet, notre quête esthétique et technologique n'est

pas sans évoquer celle prônée, jadis, par Guariche. Les affinités sont légion. Elles ont en particulier un nom : l'innovation.

L'homme a inventé une grande variété de dispositifs : balancier orientable, porte-à-faux, potence pivotante ou basculante, bras articulé à l'aide de rotules et de sphères-contrepois... Chez lui : aucun stylisme gratuit, ni détail non justifié, que ce soit techniquement ou fonctionnellement.

Pierre Guariche a mis en place les codes d'une esthétique radicale, sinon avant-gardiste. D'un côté, des lignes pures et des formes inédites. De l'autre, une dimension technique novatrice et une intelligence des matériaux, notamment pour le métal.

Concepteur-fabricant, Sammode met au service de cette nouvelle collection son expertise industrielle dans la fabrication des luminaires, en particulier la justesse de l'éclairage et une profonde connaissance du travail du métal.

Fidèles au dessin originel et intégrant des technologies contemporaines, les modèles siglés *Sammode — Pierre Guariche* bénéficient, à l'instar de l'ensemble des luminaires Sammode, d'une qualité de réalisation exceptionnelle et d'une fabrication française.

Sammode—Pierre Guariche



La lampe à poser G24, créée en 1953 | The G24 table lamp, designed in 1953.



La lampe à poser G24, ici dans un bureau | The G24 table lamp used on an office desk.

Sammode is reissuing a selection of luminaires designed in the 1950s by one of France's most important designers: Pierre Guariche.

If there was one design discipline in which he excelled it was lighting. Designer and interior architect Pierre Guariche was one of the most prolific luminaire designers of the 1950s. That much is clear from his productive collaboration with lamp manufacturer Disderot, for which he was the preferred designer, and for which he would develop more than 40 influential and groundbreaking pieces.

Pierre Guariche designed the full range of luminaires, or perhaps more accurately families of lamps—desk lamps, floor lamps, wall lamps and pendant lamps—to cover all the needs identified for a given space. His luminaires are hugely comfortable and convenient in use, with no visible light source and an appropriate quality of light, whether intended for general lighting or traffic areas, to create an atmosphere or for a specific use, soft, powerful or even diffused by reflection.

It is anything but a coincidence that Sammode has decided to reissue some of these models today. For many years, our aesthetic and technological quest has not been without

reference to that previously undertaken by Guariche himself. The affinities are legion. And they can be summed up in a single word: innovation.

The designer invented an enormous variety of solutions: the adjustable balance arm, the cantilever, the pivoting and tilting arm, the ball-jointed arm and spherical counterweights. In his designs, there is no gratuitous stylistic excess or purposeless detail, whether technically or functionally.

Pierre Guariche introduced the codes of a radical—not to say avant-garde—aesthetic. On the one hand, purity of line and totally original forms. On the other, an innovative technical dimension and a real intelligence in the use of materials, especially metal.

As a designer and manufacturer, Sammode brings to this new collection the full weight of its industrial expertise in luminaire production, and particularly lighting suitability and a deep-rooted knowledge of metalworking.

Faithful to the original designs and incorporating today's technologies, the *Sammode—Pierre Guariche* models benefit, like all Sammode luminaires, from exceptional production quality and French manufacture.

G1

lampadaire floor lamp
suspension pendant lamp
applique wall lamp
1951



[10]



G2

lampadaire
floor lamp
1951



[14]





G3

applique
wall lamp
1951

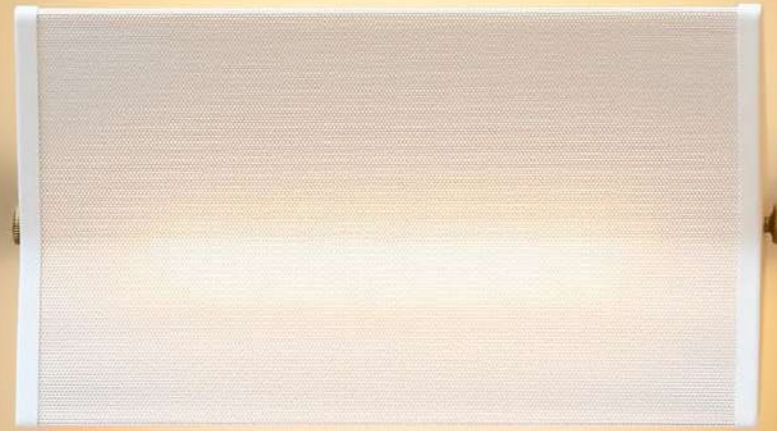

[18]

G3T

applique
wall lamp
1951

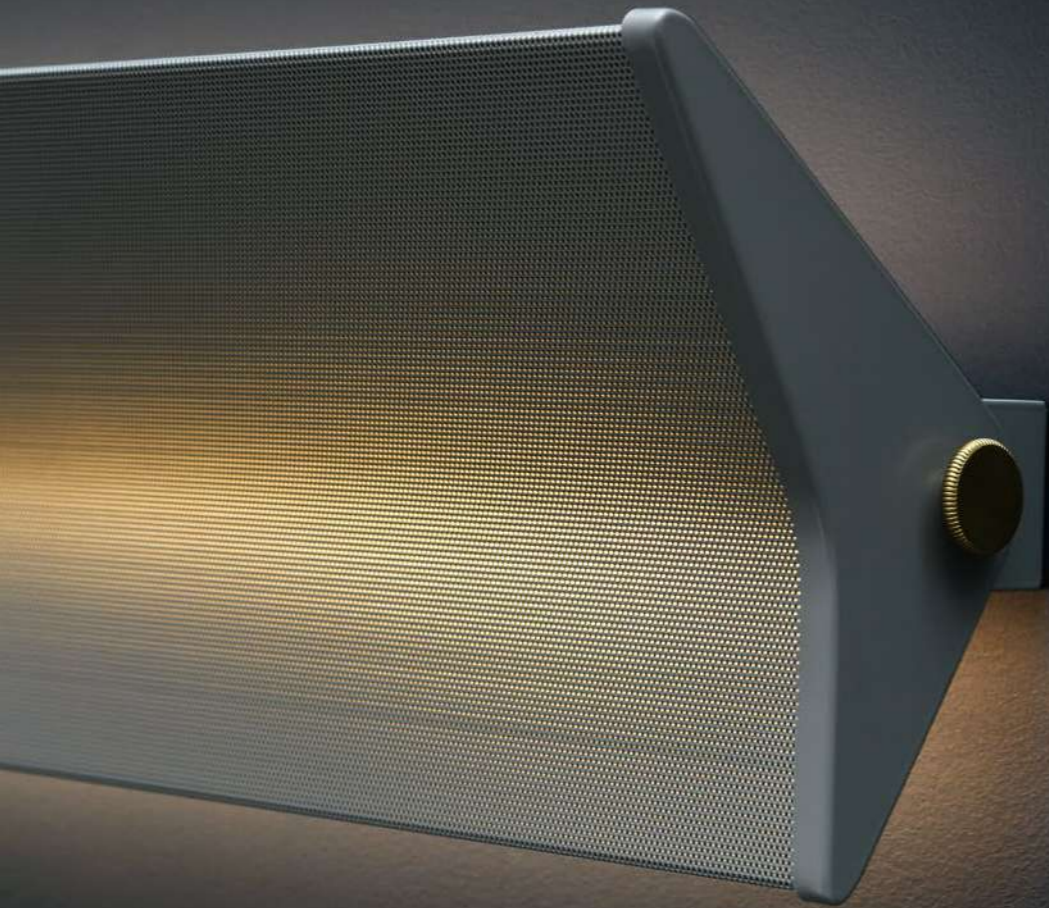

[20]

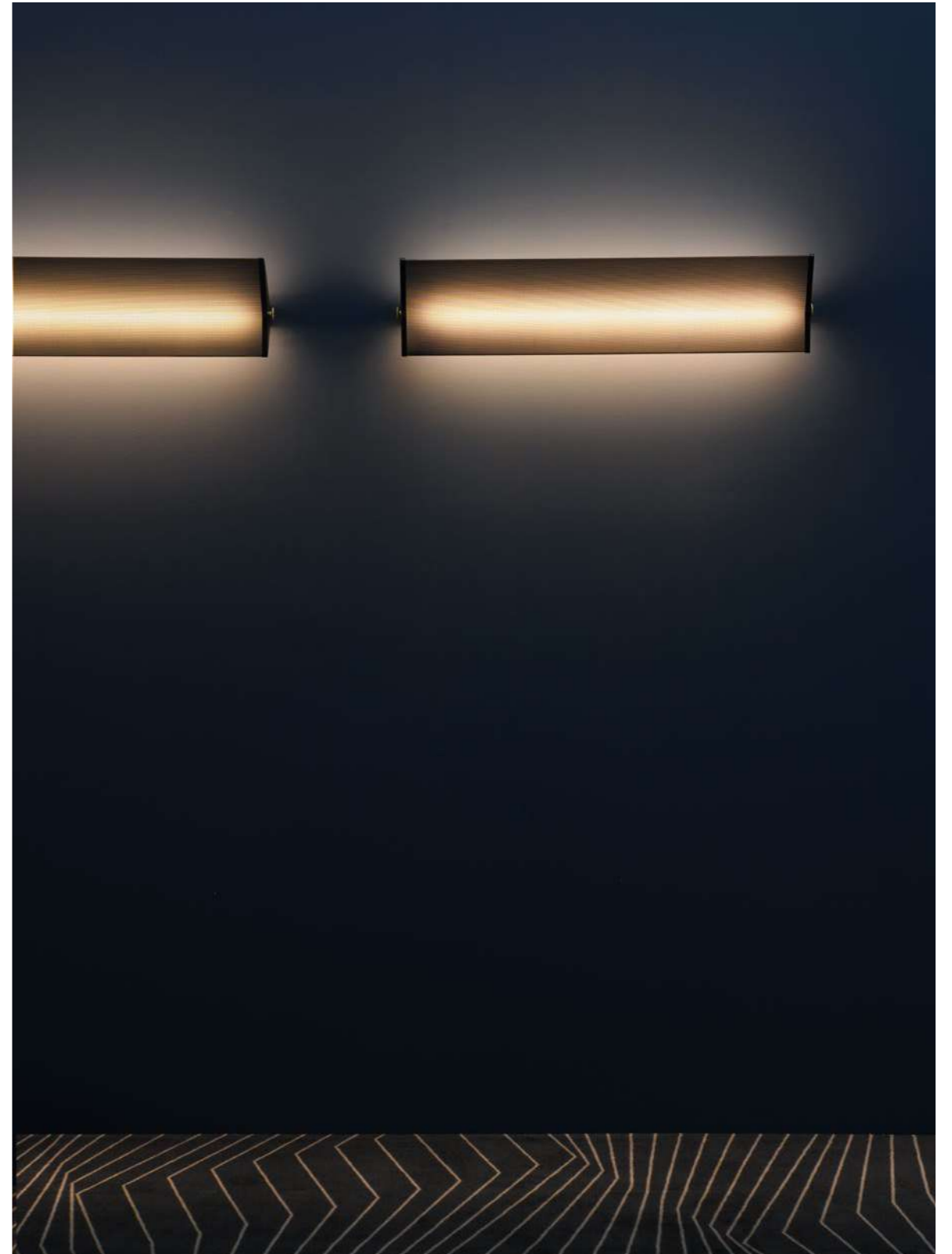

G13

plafonnier
ceiling lamp
1952



G13A

suspension
pendant lamp
1952



[24]

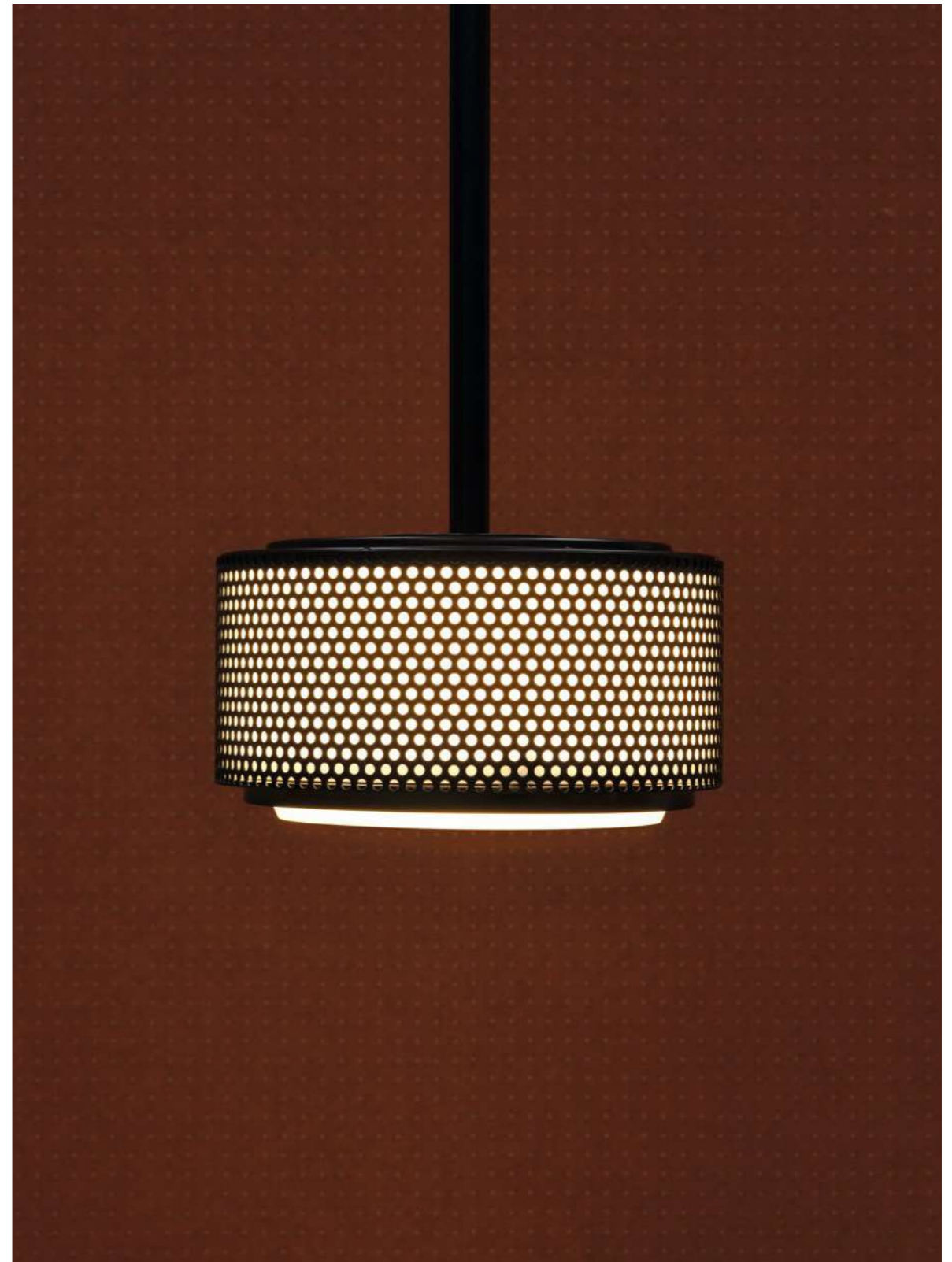

G21

lampadaire
floor lamp
1951



[26]

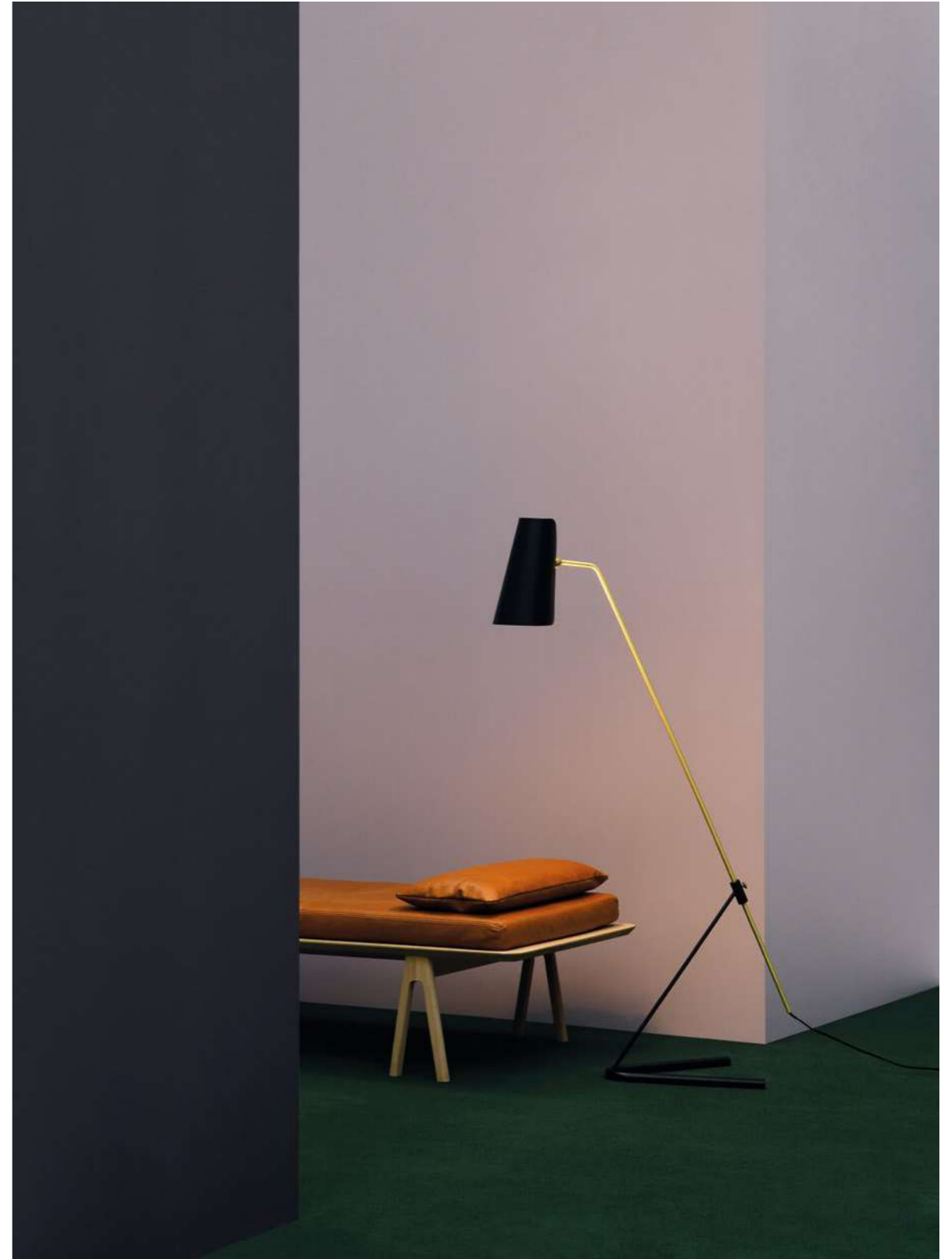



G24

lampe à poser
table lamp
1953



[30]





G25

applique wall lamp
suspension pendant lamp
1951





G30

lampadaire
floor lamp
1952

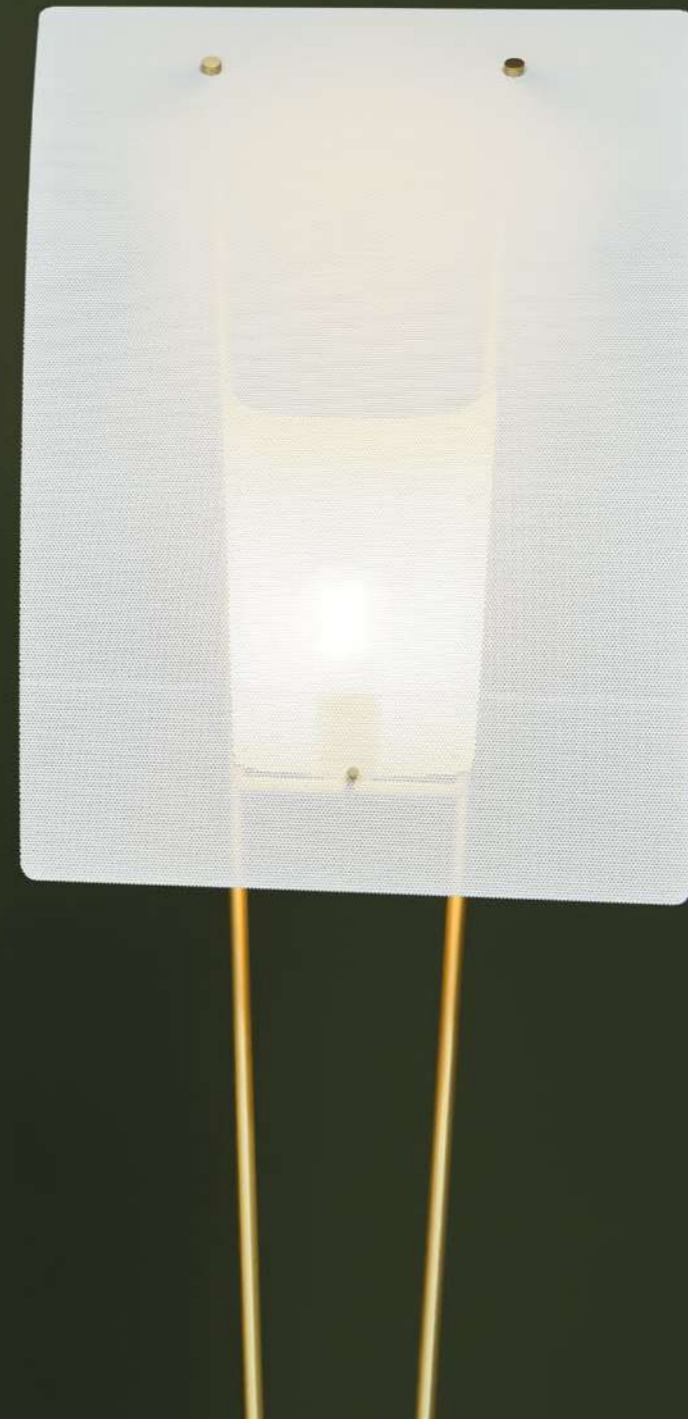
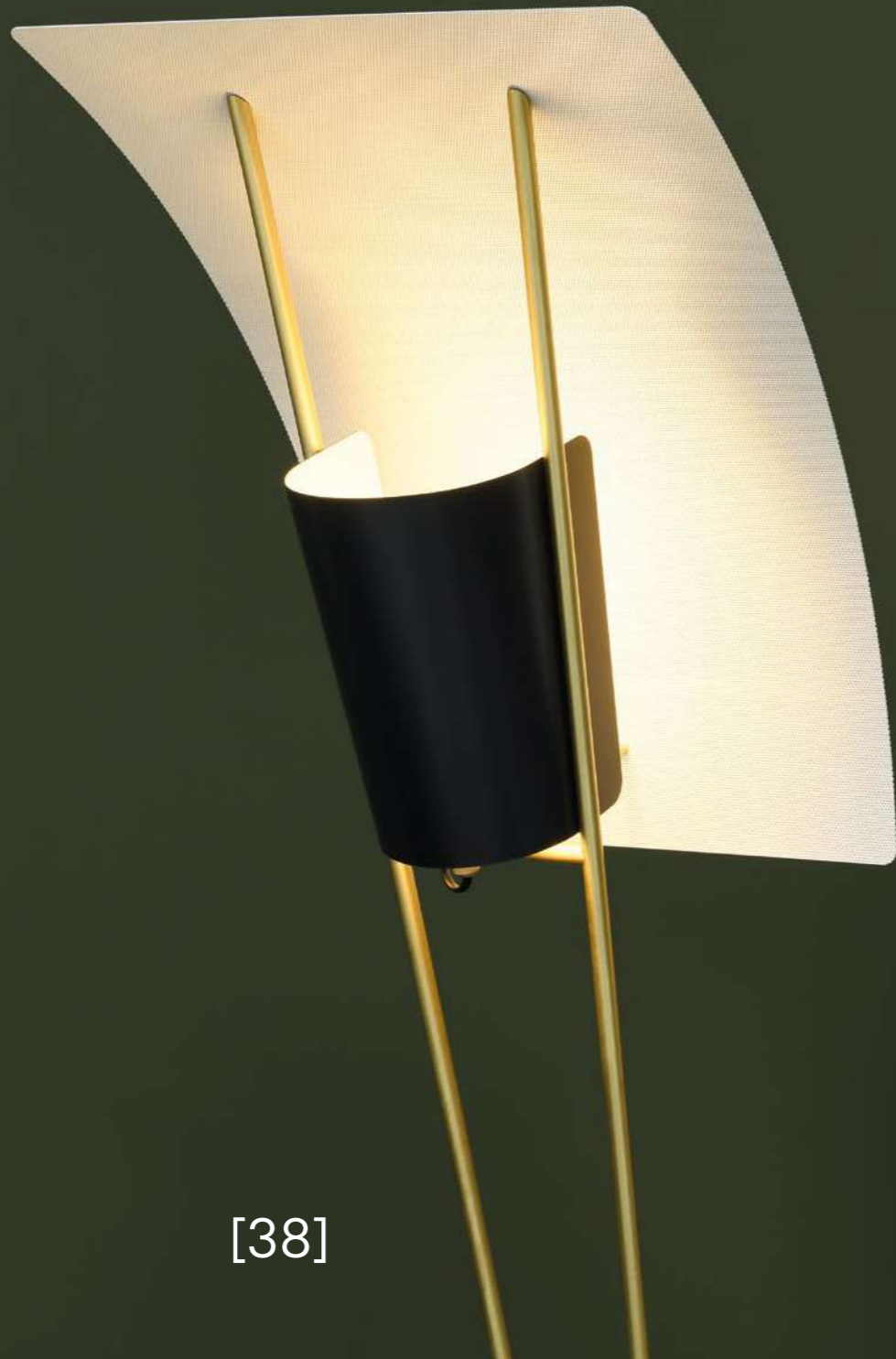

[38]

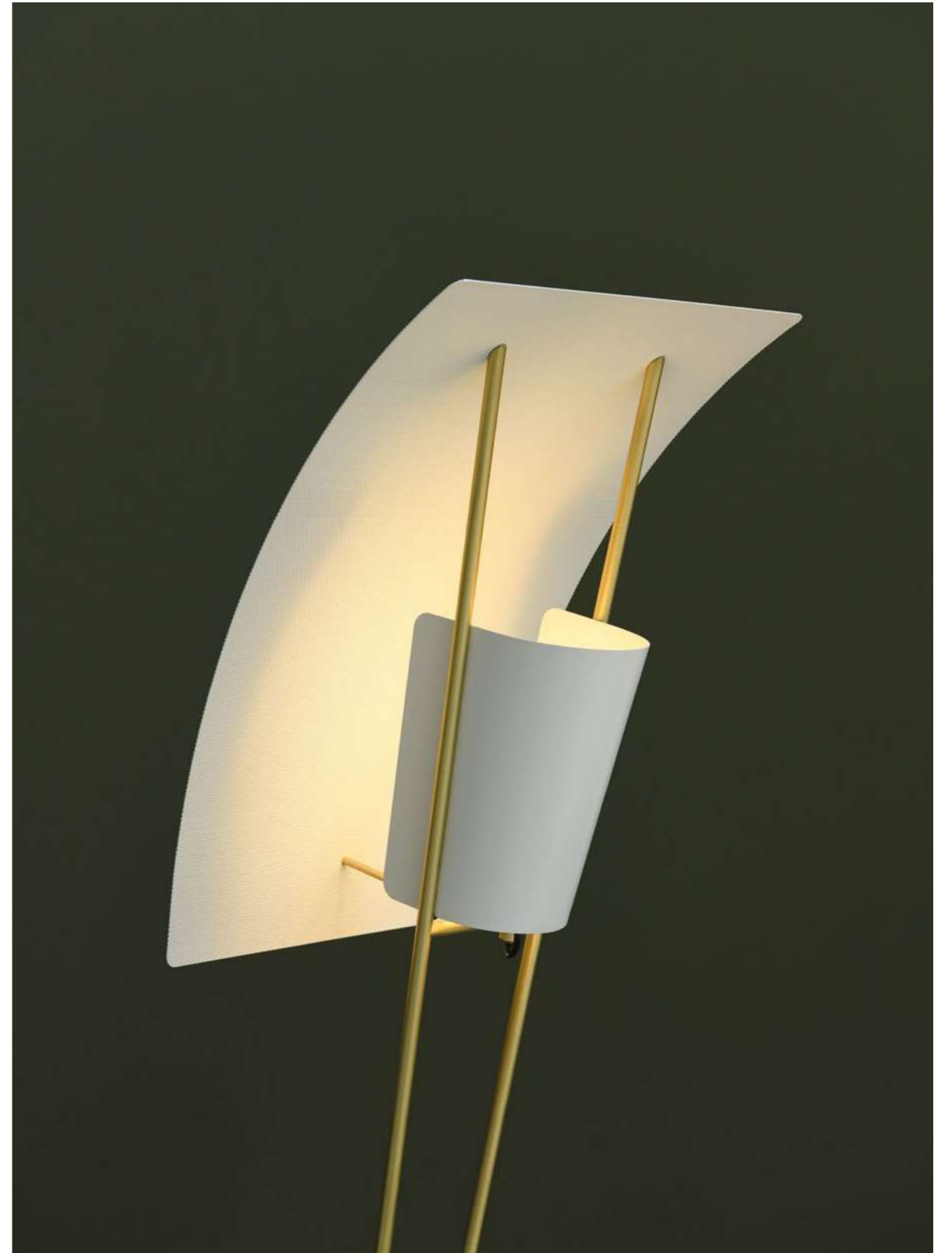

G32

applique
wall lamp
1954



[42]

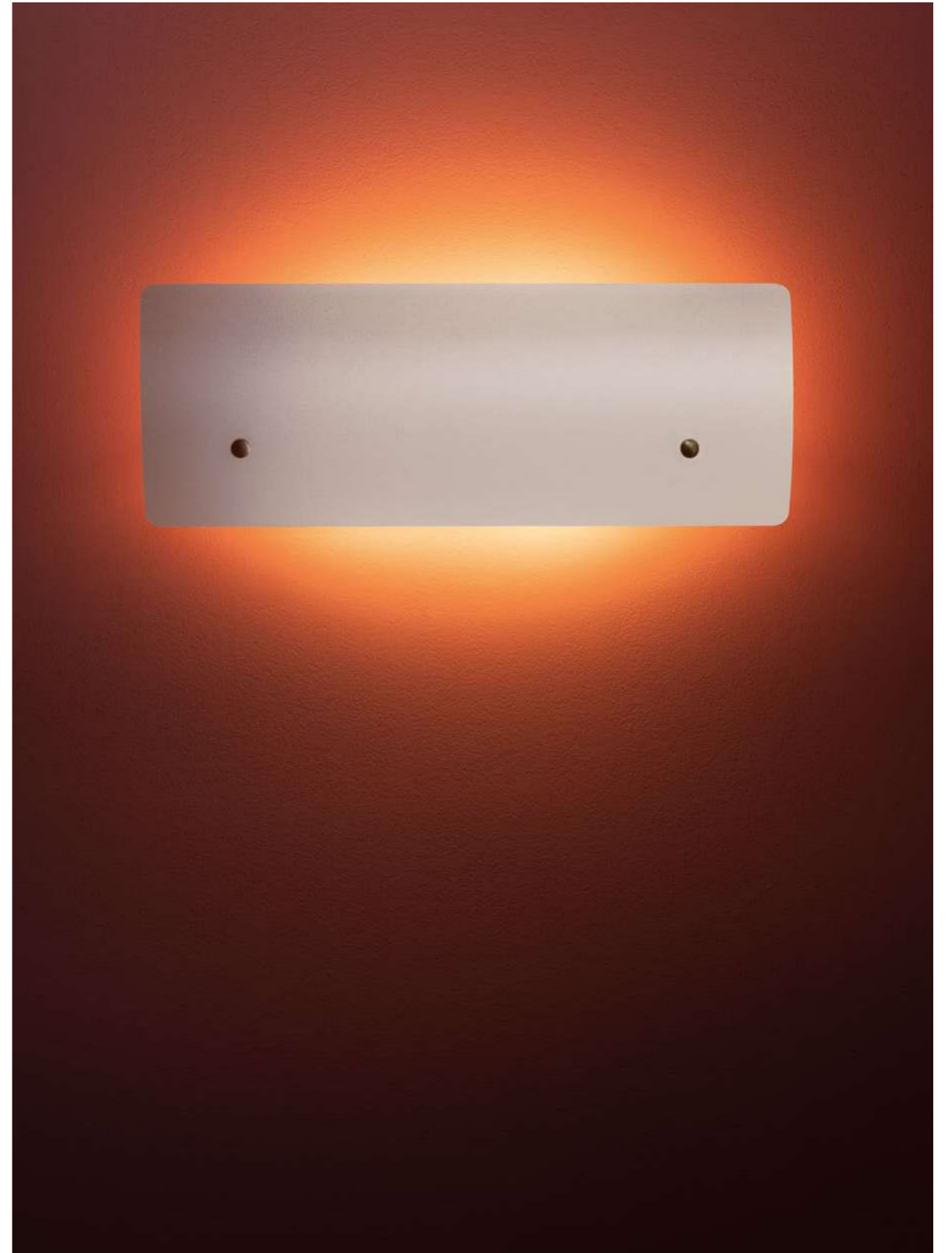

G320

applique
wall lamp
1954

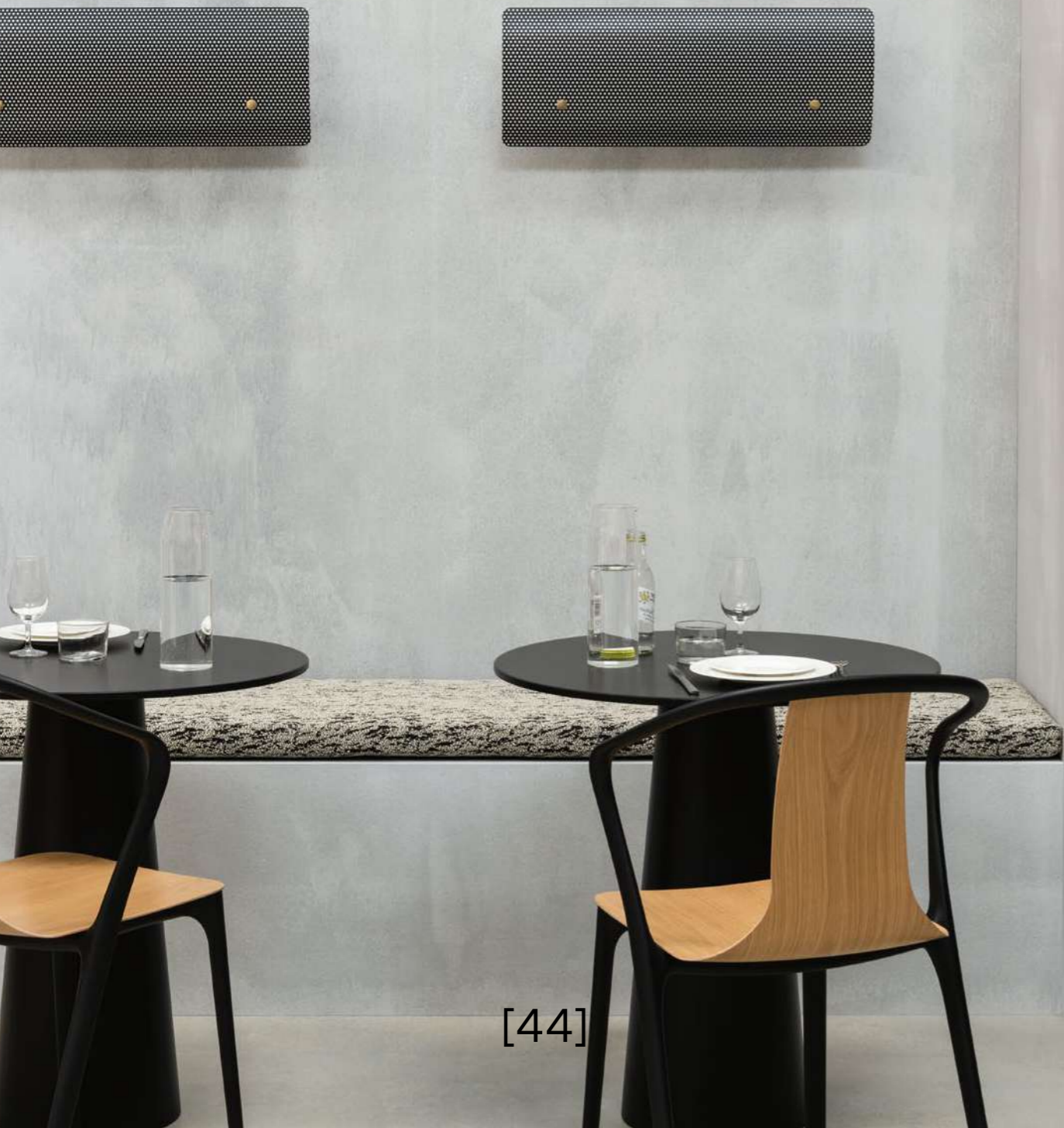

[44]

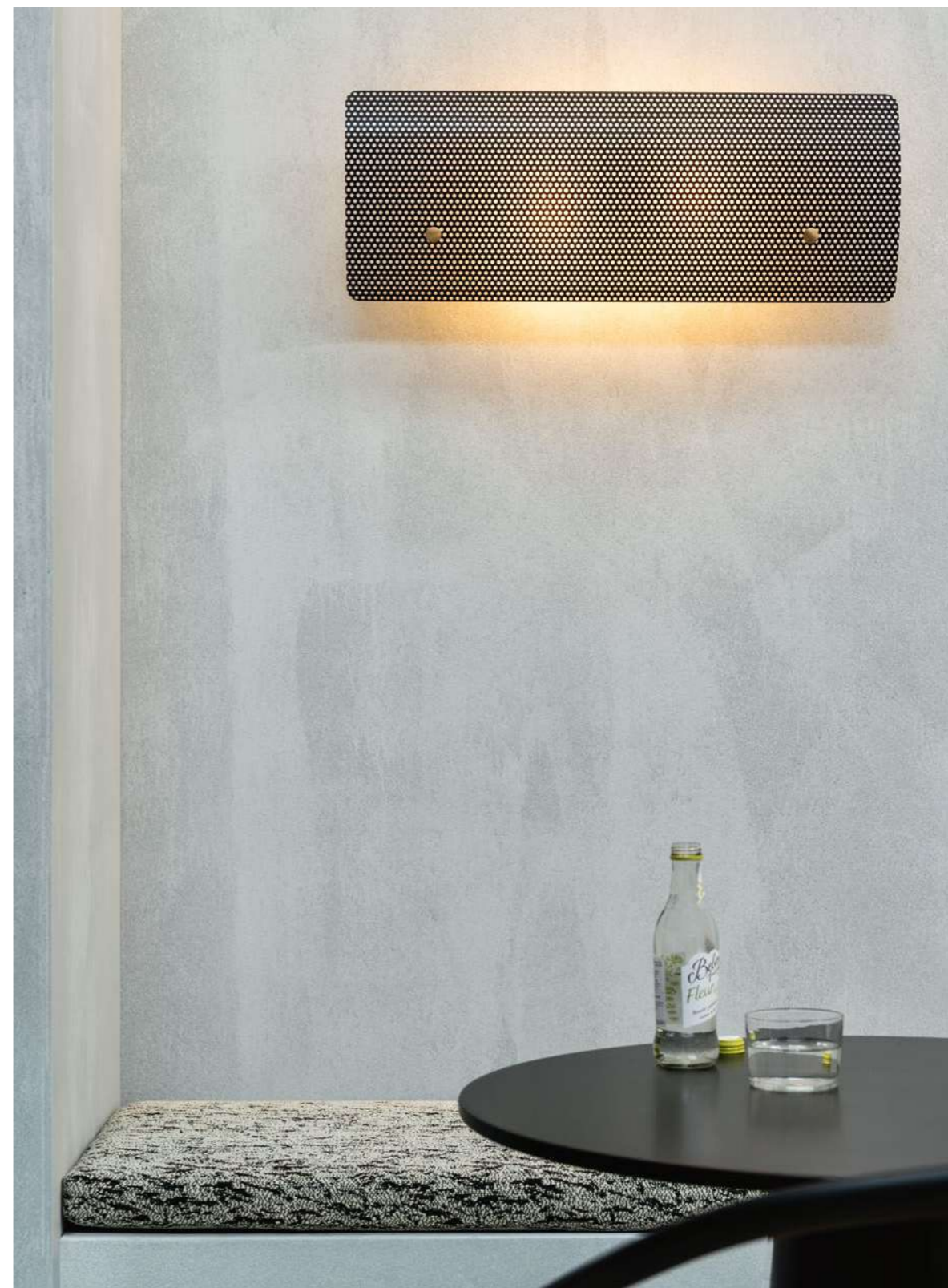

G50

lampe à poser
table lamp
1958



[46]





G54

lampadaire
floor lamp
1959



[50]

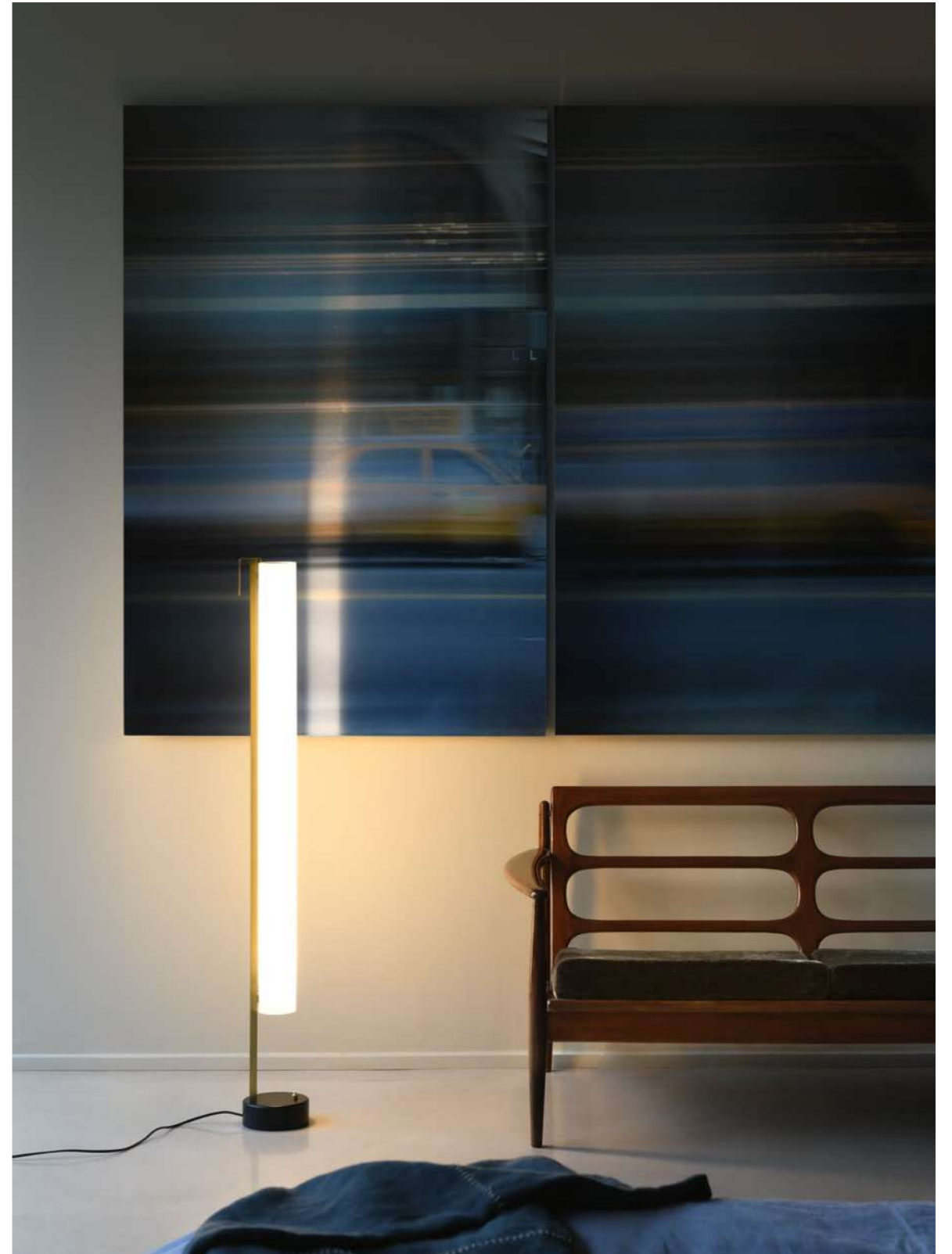

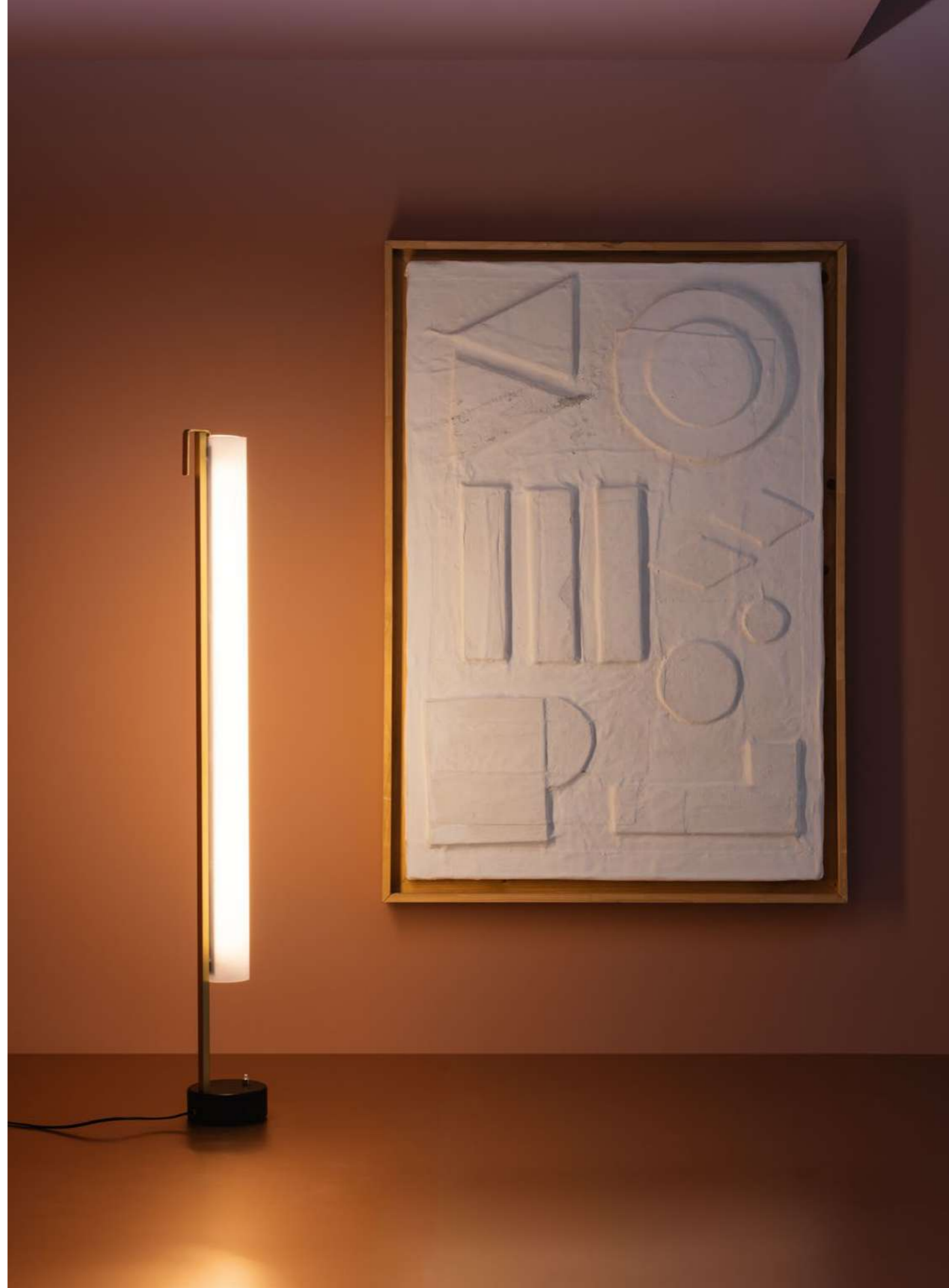

G60

lampe à poser
table lamp
1959



[54]



G61

lampe à poser
table lamp
1959



[56]

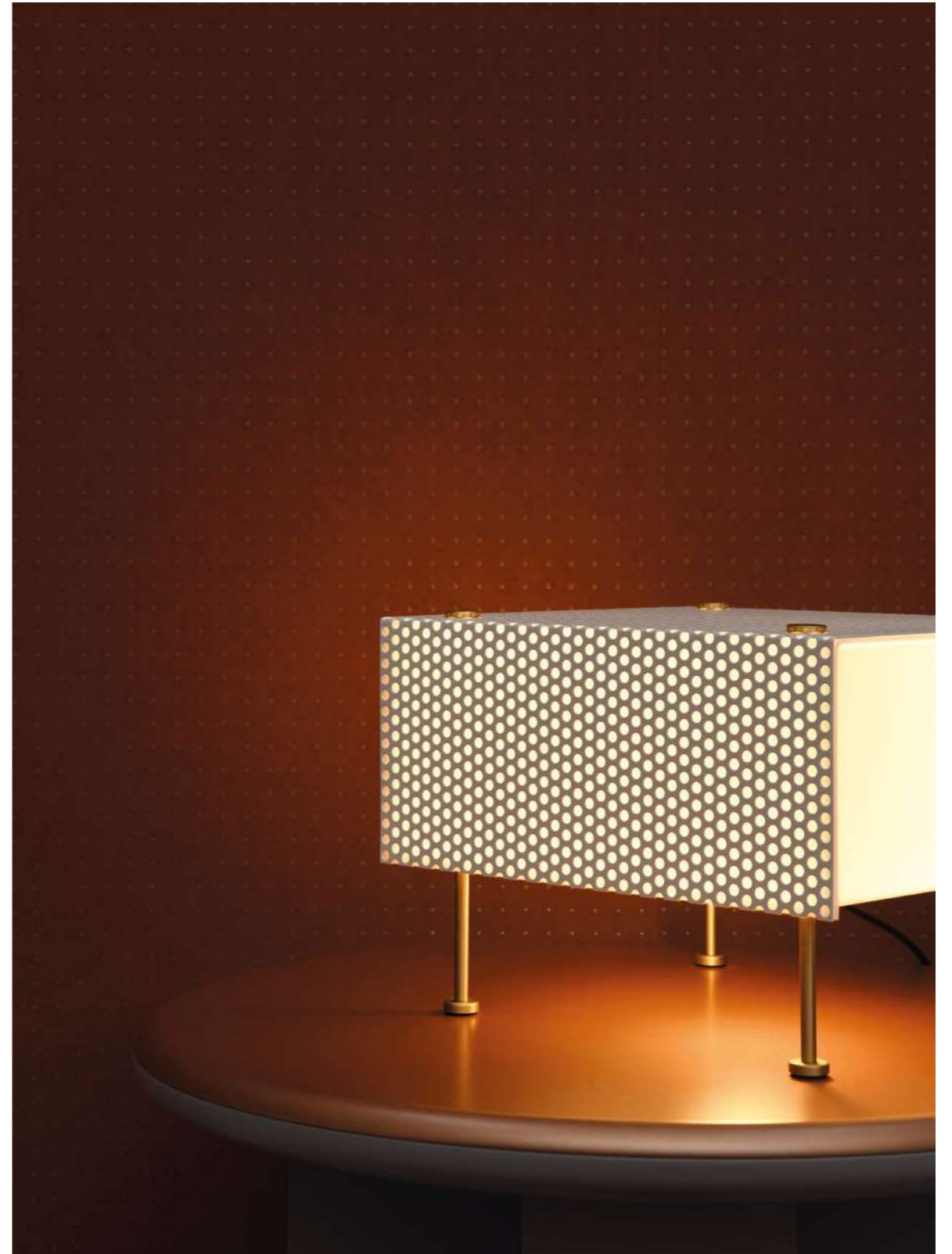

synopsis de la collection collection summary

G1

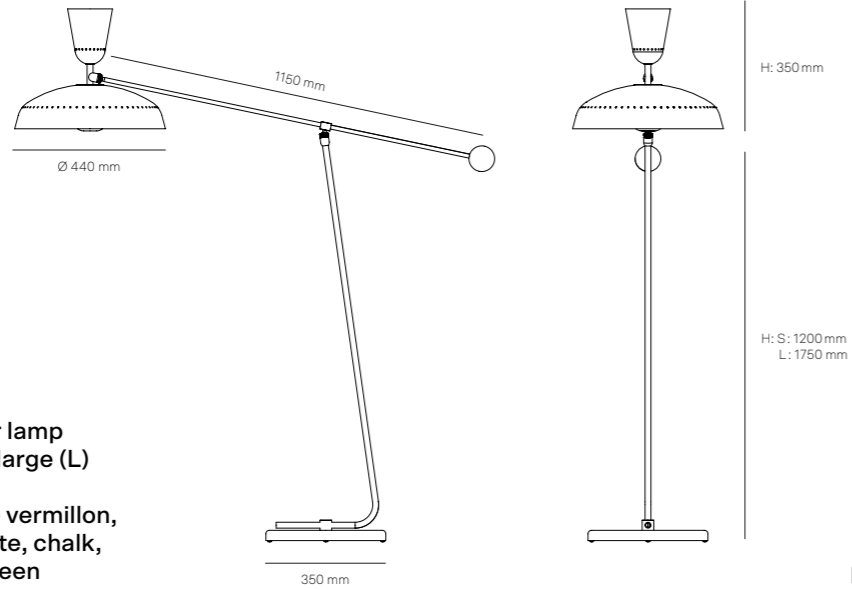

Type : lampadaire | floor lamp
Dimensions : small (S), large (L)
Couleurs | colors :
noir, blanc, craie, rouge vermillon,
vert anglais | black, white, chalk,
vermilion red, british green

p. 8-9

G1

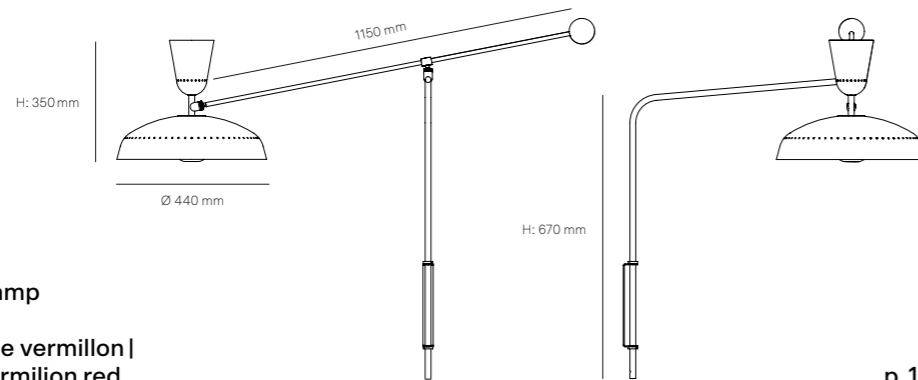

Type : applique | wall lamp
Couleurs | colors :
noir, blanc, craie, rouge vermillon |
black, white, chalk, vermilion red

p. 11

G1

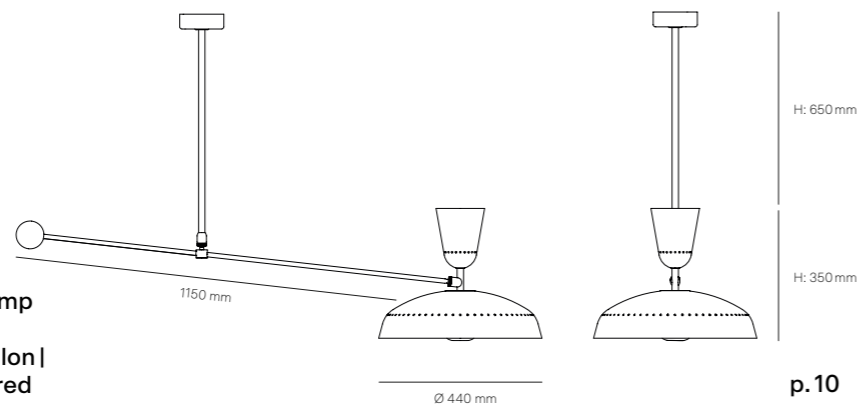

Type : suspension | pendant lamp
Couleurs | colors :
noir, blanc, craie, rouge vermillon |
black, white, chalk, vermilion red

p. 10

G2

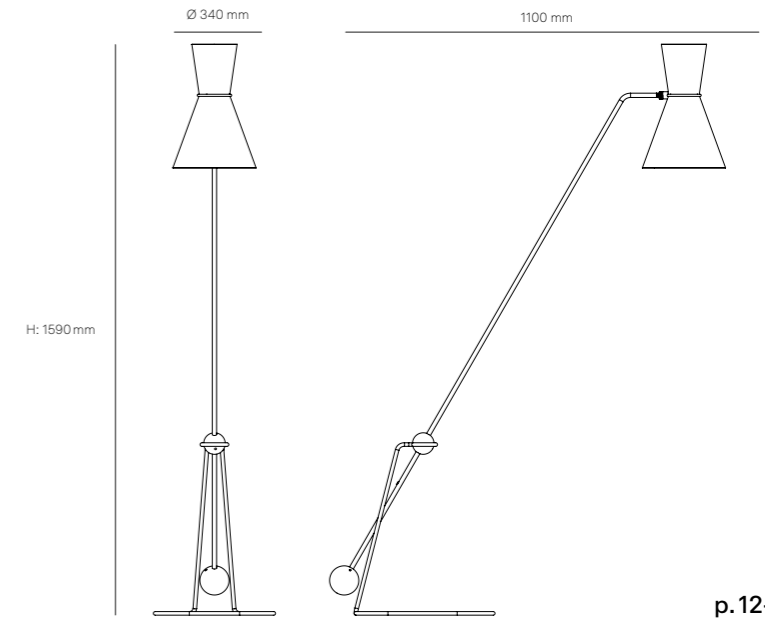

Type : lampadaire | floor lamp

p. 12-15

G3



Type : applique | wall lamp
Couleurs | colors :
noir, blanc, gris | black, white, grey



p. 16-17

G3T



Type : applique | wall lamp
Couleurs | colors :
noir, blanc, gris | black, white, grey

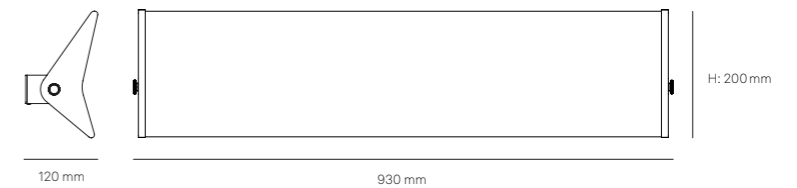

p. 18-19

G13



Type : plafonnier | ceiling lamp
Dimensions : S, M, L
Couleurs | colors :
noir, blanc, gris | black, white, grey

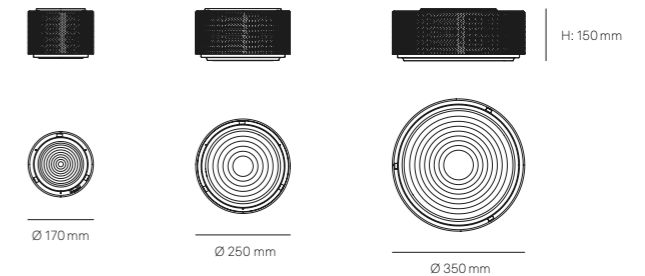

p. 20-21

G13A



Type : suspension | pendant lamp
Couleurs | colors :
noir, blanc, gris | black, white, grey

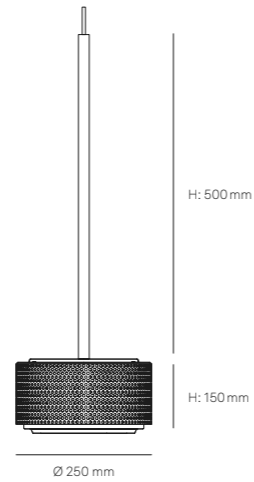

p. 22-23

G25



Type : applique | wall lamp
Couleurs | colors :
noir-blanc | black-white

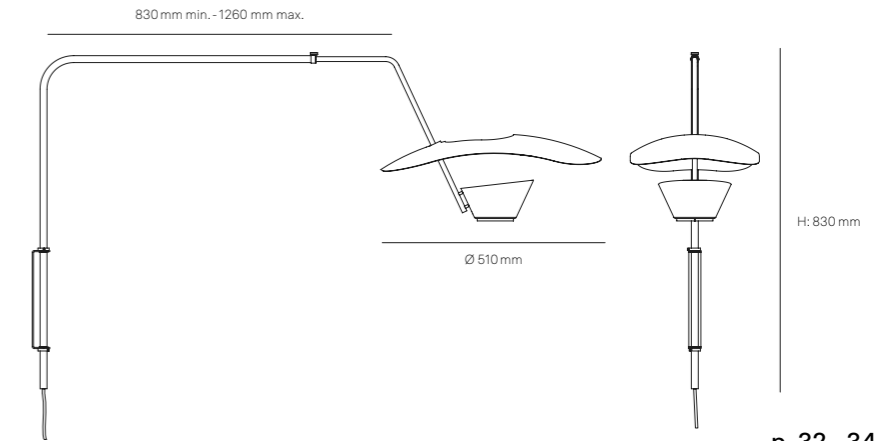

p. 32 - 34

G21



Type : lampadaire | floor lamp
Couleurs | colors :
blanc-blanc, noir-blanc |
white-white, black-white

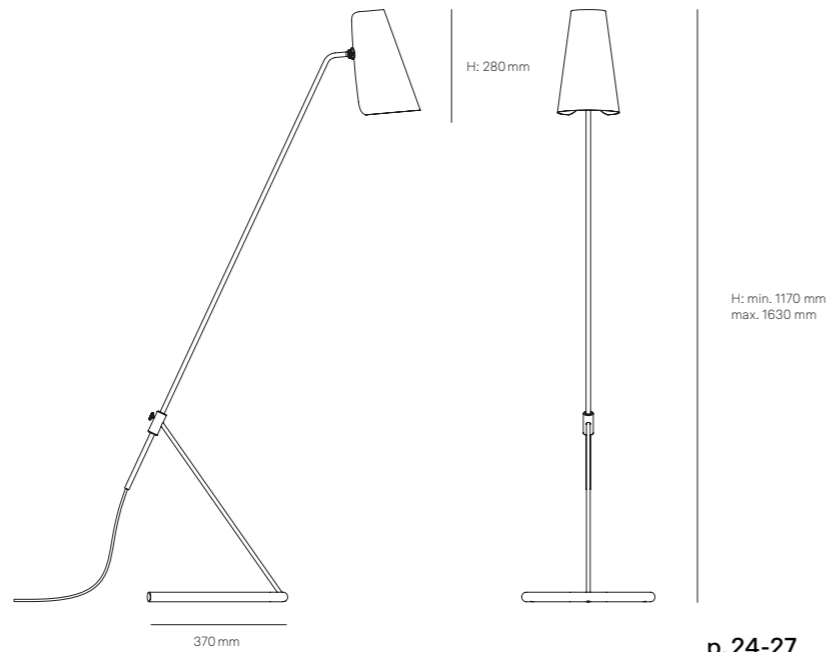

p. 24-27

G25



Type : suspension | pendant lamp
Couleurs | colors :
noir-blanc | black-white

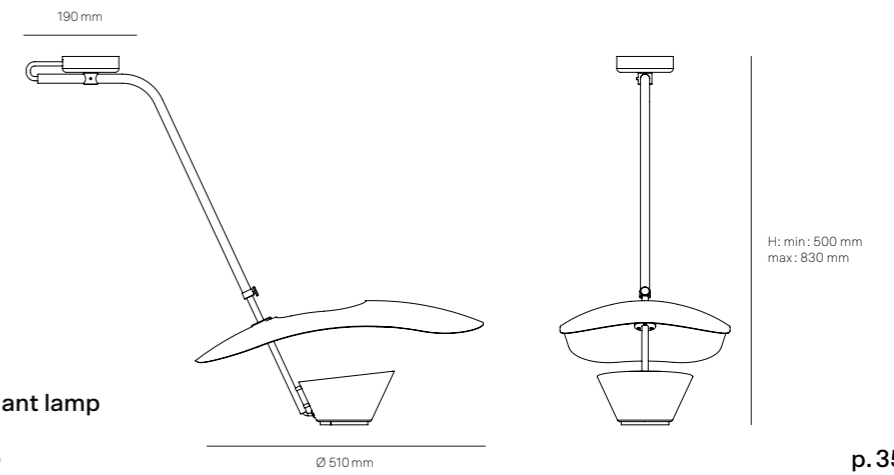

p. 35

G24



Type : lampe à poser | table lamp
Couleurs | colors :
noir, sable, rouge vermillon, vert anglais
black, sand, vermilion red, british green

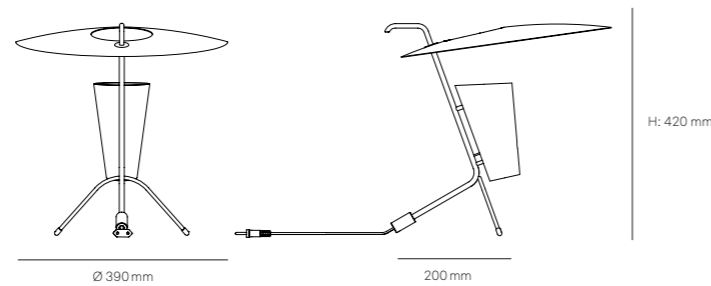

p. 28-31

G30



Type : lampadaire | floor lamp
Couleurs | colors :
noir-blanc, blanc-blanc | black-
white, white-white

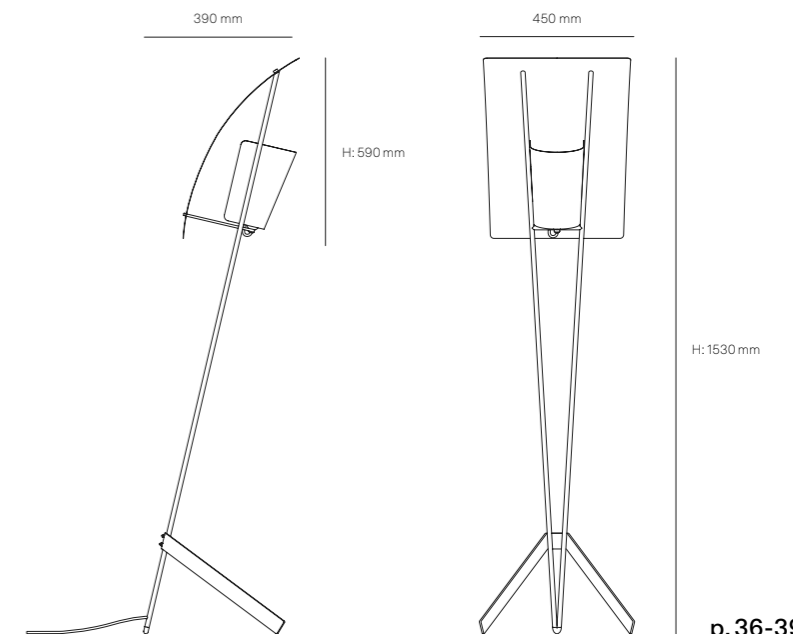

p. 36-39

G32



Type : applique | wall lamp
Couleurs | colors :
noir, blanc | black, white

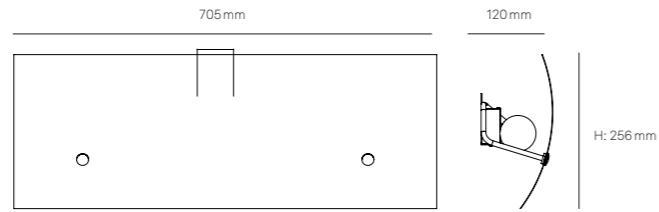

p. 40-41

G320



Type : applique | wall lamp
Couleurs | colors :
noir, blanc | black, white

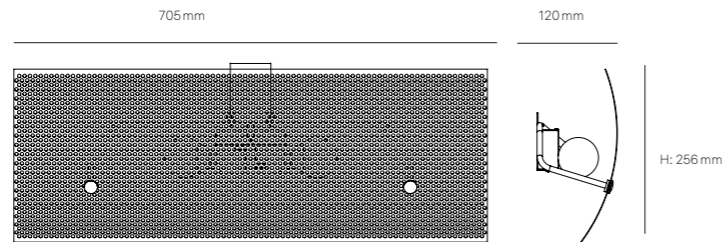

p. 42-43

G50



Type : lampe à poser | table lamp
Couleurs | colors :
noir, blanc | black, white

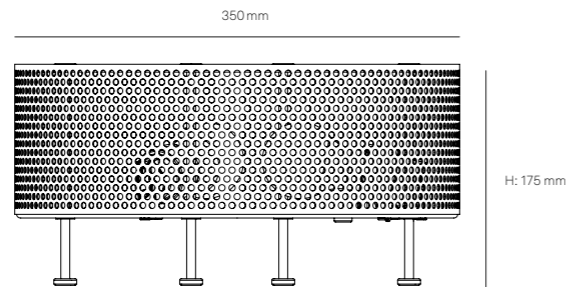

p. 44-47

G54



Type : lampadaire | floor lamp

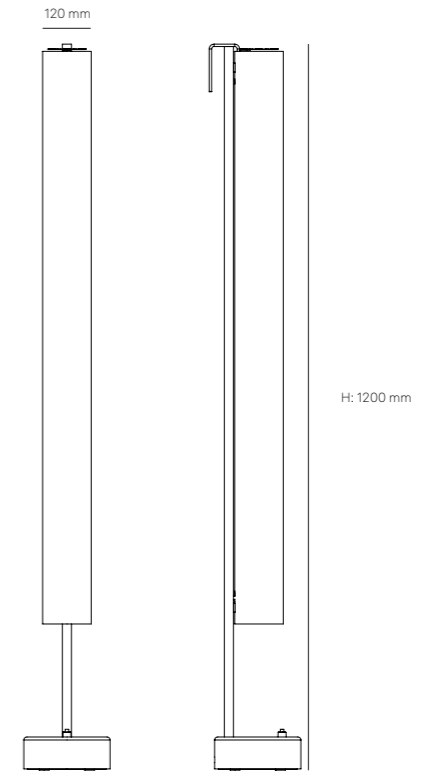

p. 48-51

G60



Type : lampe à poser | table lamp
Couleurs | colors :
noir-blanc | black-white

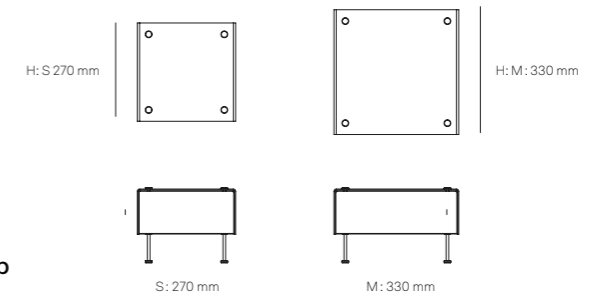

p. 52-53

G61



Type : lampe à poser | table lamp
Couleurs | colors :
blanc-blanc | white-white

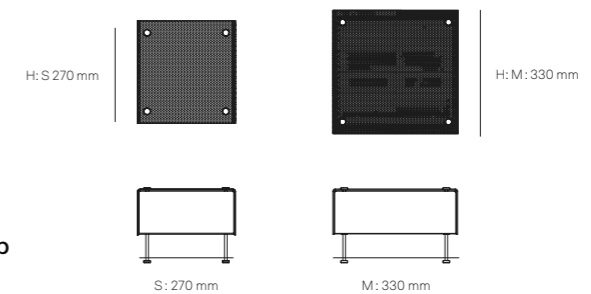

p. 54-55

Retrouvez nos gammes sur notre e-shop : studio.sammode.com

Professionnel ou particulier, vous pouvez obtenir un conseil, un devis ou une solution, en envoyant un e-mail à l'adresse studio@sammode.com. Vous pourrez apprécier l'étendue de notre savoir-faire, la force de nos engagements et la qualité de nos matériels, durables et intemporels.

Find out more about our luminaires on our e-shop: studio.sammode.com

To receive an advice, a quote or a solution please send an e-mail to studio@sammode.com. You will appreciate the extent of our know-how, the force of our commitment and the quality of our materials, durable and timeless.

Siège social & showroom professionnel (sur rendez-vous) | Head office & professional showroom (by appointment):
24 rue des Amandiers
F-75020 Paris

Retrouvez la liste de nos boutiques sur notre e-shop | Find the list of all our boutiques on our e-shop: studio.sammode.com

• Instagram
• LinkedIn
• Facebook
• Pinterest
[@sammode.lighting](https://www.instagram.com/sammode.lighting)

—
studio.sammode.com
studio@sammode.com
T+33 (0) 143 144 145

Direction artistique |
Art direction:
Normal Studio
normalstudio.fr

Conception graphique |
Graphic design:
Fanny Le Bras

Photographie | Photography:
© Morgane Le Gall
morganelegall.com

Réalisation | Production:
Aurélie des Robert

Textes | Texts:
Christian Simenc

Impression | Printing:
Art & Caractère

Photos d'archives et photos extraites des magazines *Décor d'Aujourd'hui* n°87, 1954 et *Maison Française* n°211, 1967 | Archives photos and extracts from interior design magazines *Décor d'Aujourd'hui* N°87, 1954 and *Maison Française* N°211, 1967.

© Sammode 09/2024
Sous réserve de modifications.
Subject to changes.

Remerciements |
Acknowledgments:

- Page 8 : Miroir, Hélène Népomiatzi
- Page 10 : Banc Bertoia de Harry Bertoia, Knoll chez RBC Mobilier
- Page 11 : Fauteuil Transat époque 1920/1930, courant moderniste, "Studio Mallet-Stevens"
 - Livres, Mona lisait
 - Moquette collection Les Best, Balsan
- Page 12 : Fauteuil Major Tom, design Thomas Dariel, Maison Dada
 - Table d'appoint Loren, design Draga & Aurel pour Baxter, Silvera
 - Papier peint Dots, collection Le Corbusier, Arte
 - Moquette, collection Sweet Dreams, Balsan
- Page 13 : Papier peint Dots, collection Le Corbusier, Arte
- Page 14 : Fauteuil et ottoman Fanny, éditions L'Atelier 55, L'Atelier 55
 - Moquette, collection Sweet Dreams, BALSAN
- Page 15 : Miroirs, création Studio KO, Studio KO
- Page 16/17 : Fauteuil de Nanna et Jørgen Ditzel, en tissu exclusif Pierre Frey, The Conran Shop
 - Objet décoratif en marbre, design Elisa Ossine, Salvatori chez Silvera Bois, Oberflex
- Page 19 : Moquette Mikado, Balsan
- Page 22 : Fauteuil réédité de Finn Juhl, Triode Design Verrerie, XL Boom chez Rouge Ardoise
- Page 23 : Papier peint, collection Le Corbusier, Arte
- Page 25 : Lit de repos Level en chêne et cuir, Woud chez Rouge Ardoise
 - Moquette collection Les Best, Balsan
- Page 27 : Fauteuil vintage d'Eileen Gray, Ecart International chez Rouge Ardoise
 - Moquette, Balsan
- Page 28 : Bureau en métal et verre des années 60/70, XXO
- Page 29 : Bureau en métal et verre des années 60/70, XXO

- Page 30/31 : Guéridon haut Eros en marbre noir Marquina d'Angelo Mangiarotti, RBC Mobilier
- Page 34 : Shaker desk, Ladies & Gentleman et fauteuil, réédition, House of Finn Juhl, Triode Design
 - Papier peint collection Le Corbusier, Arte
 - Moquette, Balsan
- Page 38 : Fauteuil de Gio Ponti, Molteni chez RBC Mobilier
 - Moquette, Balsan
- Page 40 : Carrelage Pack, 41zero42, Surface
 - Tabouret haut Tractor Stool et plateaux Stacking Tray, design BassamFellows, Triode
- Page 42 : Chaises Belleville, Ronan & Erwan Bouroullec pour Vitra
 - Guéridons Container, Marcel Wanders pour Moooi
 - Tissu Baltic, collection Borealis par Lelièvre Signature, Lelièvre
- Page 43 : Chaises Belleville, Ronan & Erwan Bouroullec pour Vitra
 - Guéridons Container, Marcel Wanders pour Moooi
 - Tissu Baltic, collection Borealis par Lelièvre Signature, Lelièvre
- Page 45 : Linge de lit, Harmony Textile
- Page 47 : Tabouret TriAngle, design Aldo Bakker pour Karakter, SILVERA
 - Tissu À Contre-Jour, Dedar
- Page 48 : Chaise vintage Vilbert, Verner panton pour Ikea
 - Moquette, collection Les Best, Balsan
 - Papier peint Dots, collection Le Corbusier, ARTE
- Page 49 : Linge de lit, Harmony Textile
 - Banc vintage, design Grete Jalk
 - Œuvre, Manolo Chrétien
- Page 51 : Bas-relief en plâtre, FD63 pour L'Atelier 55
- Page 52/53 : Console en métal, Stéphane Ducatteau
- Page 54 : Lit de repos, Vonnegut Kraft, Triode Design
 - Table d'appoint, design Jaime Hayon pour Arflex, Siltec

- Papier peint, collection Le Corbusier, Arte
- Moquette, Balsan
- Page 55 : Table d'appoint, design Jaime Hayon pour Arflex, Siltec
- Papier peint, collection Le Corbusier, Arte

